

Approval sheet

Customer: _____

Modelname: JTA10MZXH-01

Spec NO: _____

Date: 2016.1.13

Version: Ver 02

- Preliminary Specification**
- Final Specification**

For Customer's Acceptance

Approved by	Content

Approved by	Reviewed by	Prepared by

Contents

1. General Specification.....	4
2. Mechanical Drawing.....	5
3. Block Diagram.....	6
4. Interface Pin Function.....	7
5. Absolute Maximum Ratings.....	8
6. Electrical Characteristics.....	9
7. Optical Characteristics.....	10
8. Timing Characteristics.....	13
9. Standard Specification for Reliability.....	15
10. General Precautions.....	16
11. Packing Method.....	16

1. General Specification

Item	Contents	Unit
LCD TYPE	TFT/TRANSMISSIVE	
MODULE SIZE (W*H*T)	235.00*143.00*5.00	MM
ACTIVE SIZE (W*H)	222.72*125.28	MM
PIXEL PITCH (W*H)	0.2175*0.2088	MM
NUMBER OF DOTS	1024*600	
DIVER IC	HX8282-A+HX8696-A	
INTERFACE TYPE	LVDS	
TOP POLARIZER TYPE	ANTI-GLARE	
RECOMMEND VIEWING DIRECTION	12	O'CLOCK
GRAY SCALE INVERSION DIRECTION	6	O'CLOCK
COLORS	65K	
BACKLIGHT TYPE	39-CHIP WHITE LED	
TOUCH PANEL TYPE	WITHOUT	

3. Block Diagram

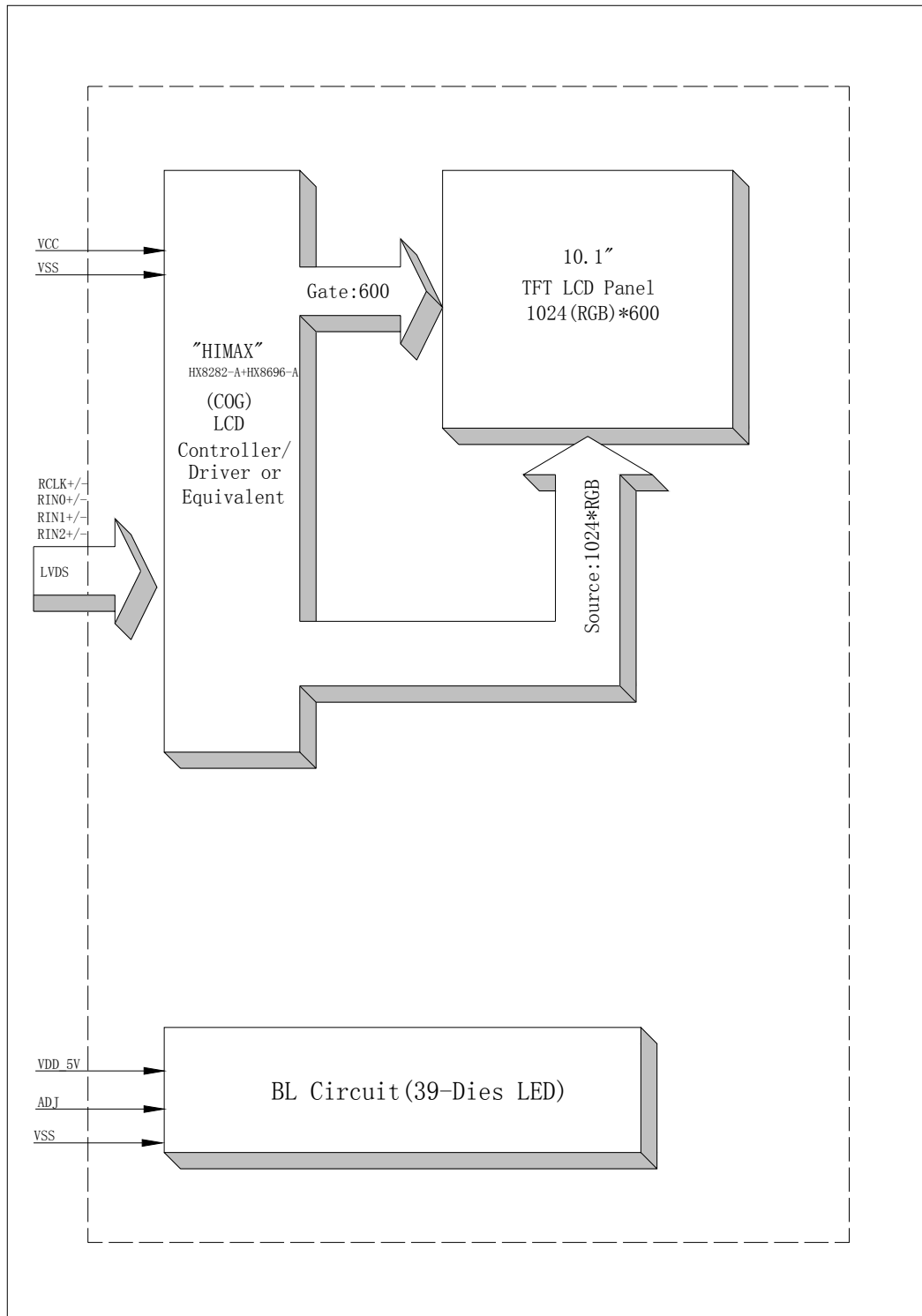

4. Interface Pin Function

Pin No.	Symbol	Description
1	VCC	Power Voltage for digital circuit
2	VCC	Power Voltage for digital circuit
3	VSS	Ground
4	VSS	Ground
5	RIN0-	-LVDS differential data input
6	RIN0+	+ LVDS differential data input
7	VSS	Ground
8	RIN1-	- LVDS differential data input
9	RIN1+	+ LVDS differential data input
10	VSS	Ground
11	RIN2-	- LVDS differential data input
12	RIN2+	+ LVDS differential data input
13	VSS	Ground
14	RCLK-	- LVDS differential data input
15	RCLK+	+ LVDS differential data input
16	VSS	Ground
17	VDD_5V	Backlight power input
18	VDD_5V	Backlight power input
19	ADJ	Backlight driver chip enable
20	VSS	VSS

5. Absolute Maximum Ratings

Parameter	Symbol	Min	Max	Unit
Supply voltage for analog	VCC	-0.3	5	V
Supply voltage for logic	VCC	-0.5	5	V
Supply current (One LED)	I _{LED}		60	mA
Operating temperature	T _{OP}	-20	+70	°C
Storage temperature	T _{ST}	-30	+80	°C

Note: The absolute maximum rating values of this product are not allowed to be exceeded at any times. Should a module be used with any of the absolute maximum ratings exceeded, the characteristics of the module may not be recovered, or in an extreme case, the module may be permanently destroyed.

6. Electrical Characteristics

6.1 Input Power

Item	Symbol	Min	Typ.	Max	Unit	Applicable terminal
Supply Voltage for Analog	VCC	3.0	3.3	3.6	V	
Supply Voltage for Logic	VCC	3.0	3.3	3.6	V	
Input Voltage	V _{IL}	GND	-	0.3 VCC	V	
	V _{IH}	0.7 VCC	-	VCC		
Input leakage Current	I _{LKG}	-		-	μA	

6.2 Backlight Driving Conditions

Item	Symbol	Value			Unit	Remark
		Min.	Typ.	Max.		
Voltage for LED Backlight	V _F		9.6		V	I _L =260mA
Current for LED Backlight	I _L		260		mA	
Power Consumption	P		2.496		W	
LED Life Time		30,000			Hr	Note

Note: Brightness to be decreased to 50% of the initial value at ambient temperature TA=25°C

7. Optical Characteristics

ITEM	SYMBOL	CONDITIONS	SPECIFICATIONS			UNIT	NOTE
			MIN	TYP.	MAX		
Luminance	L	$I_L = 260\text{mA}$		450		Cd/m^2	
Contrast Ratio	CR	$\theta = 0^\circ$		600			
Response Time	T_{ON}	25°C		25	40	ms	
	T_{OFF}						
CIE Color Coordinate	Red	X_R	Viewing normal angle				
		Y_R					
	Green	X_G					
		Y_G					
	Blue	X_B					
		Y_B					
	White	X_W			0.290		
		Y_W			0.330		
Viewing Angle	Hor.	θ_{X+}	$\text{CR} \geq 10$	60	70	Degree	
		θ_{X-}		60	70		
	Ver.	θ_{Y+}		60	70		
		θ_{Y-}		40	50		
Uniformity	Un			70	75	%	

Note 1: Definition of Viewing Angle θ_x and θ_y :

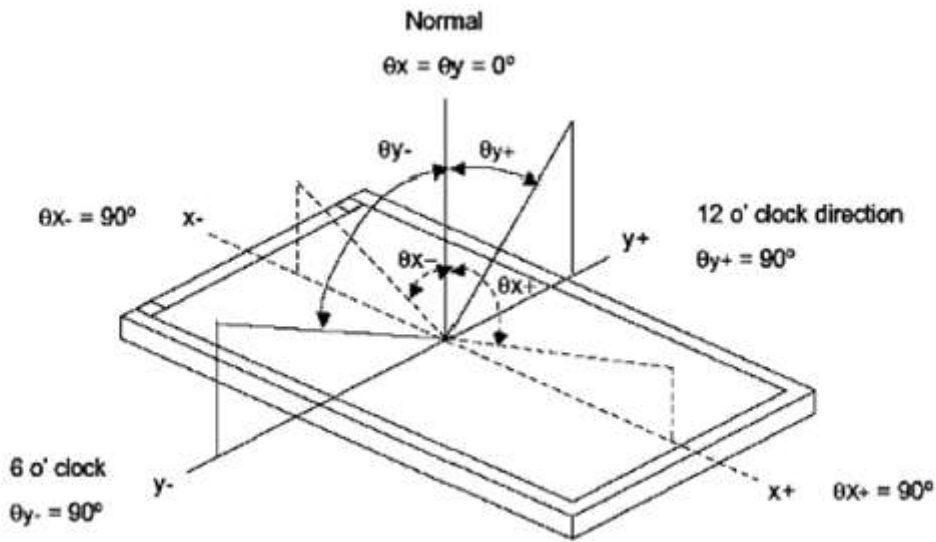

Note 2: Definition of contrast ratio CR:

$$CR = \frac{\text{Luminance of white state}}{\text{Luminance of black state}}$$

Note 3: Definition of Response Time(T_r, T_f)

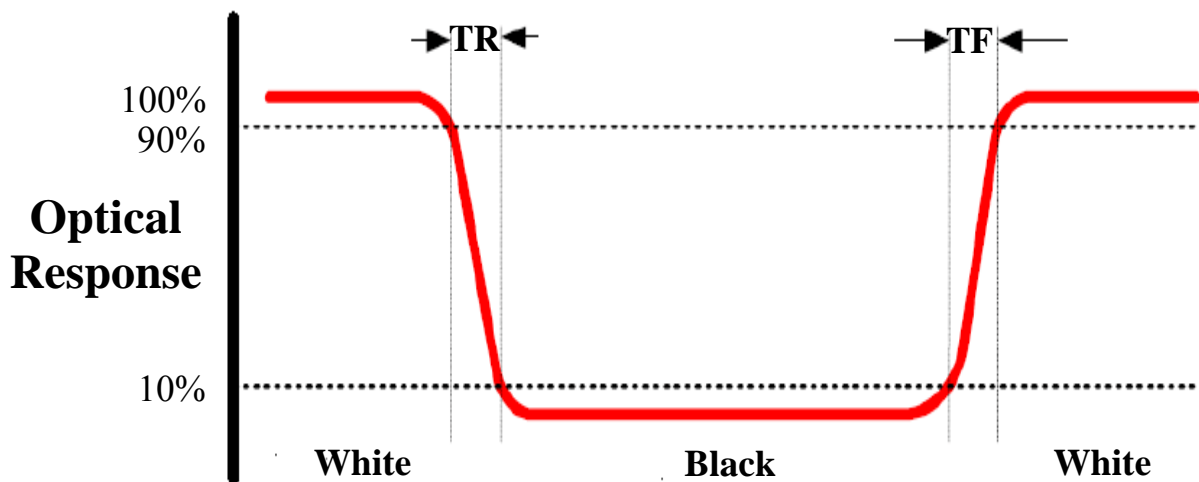

Note 4: Definition of Luminance**①The Brightness Test Equipment Setup**

Field=2° (As measuring “black” image, field=2° is the best testing condition)

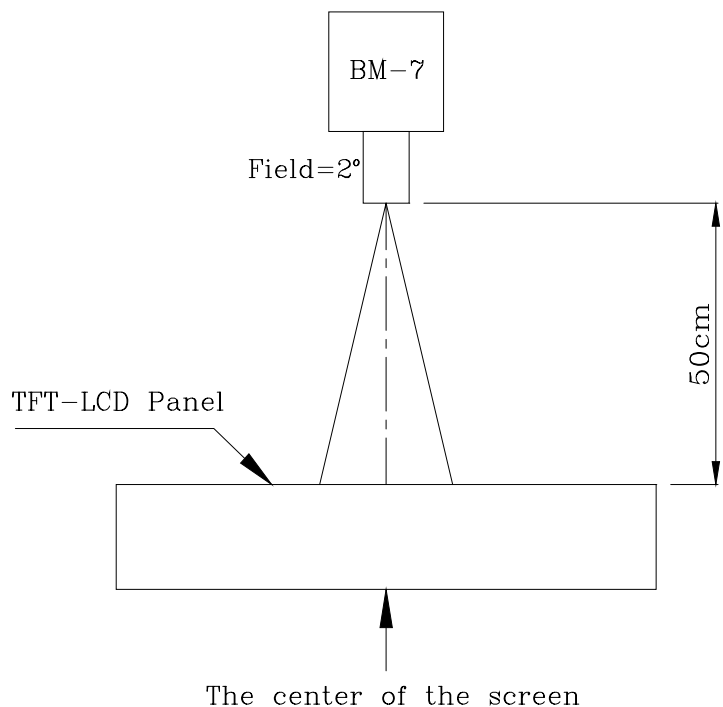
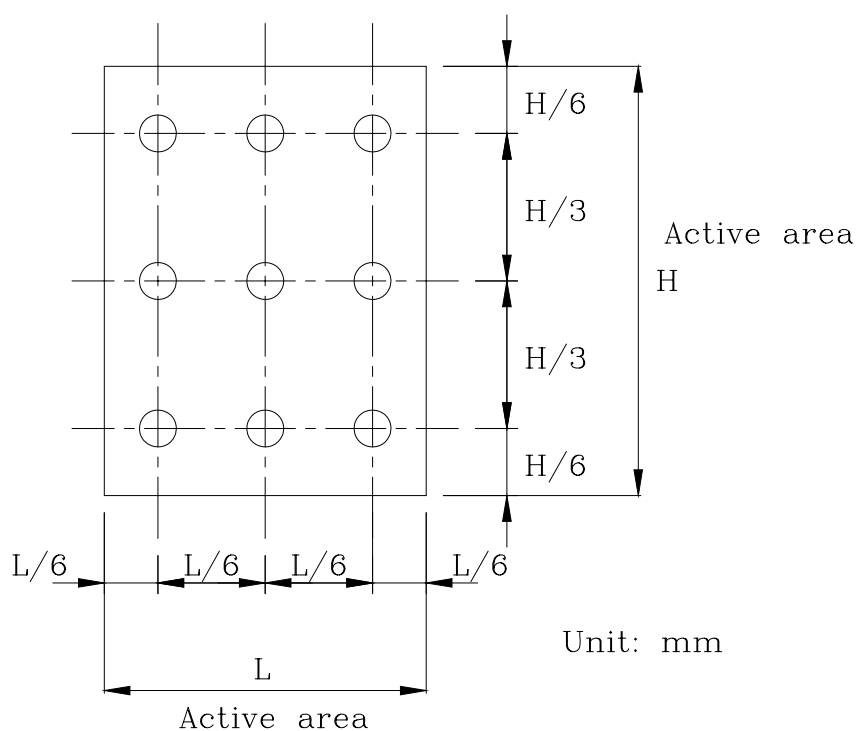
**②The Brightness Test Point Setup**

8. Timing Characteristics

8.1 LVDS Timing Diagram

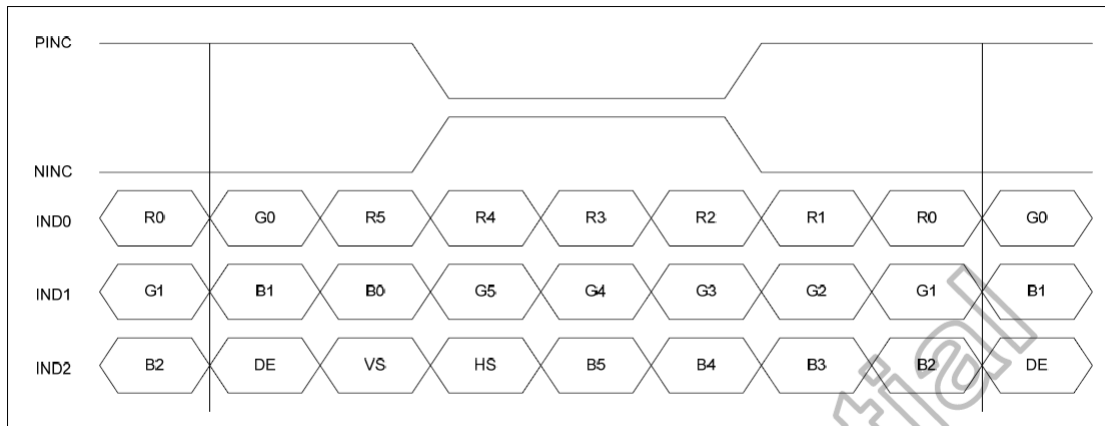

Figure 10.4: 6-bit LVDS input

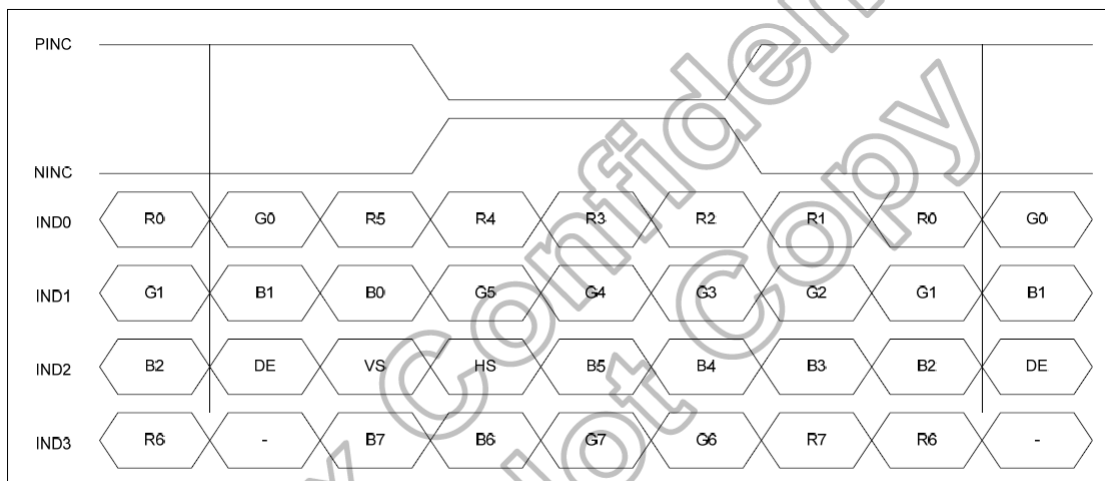
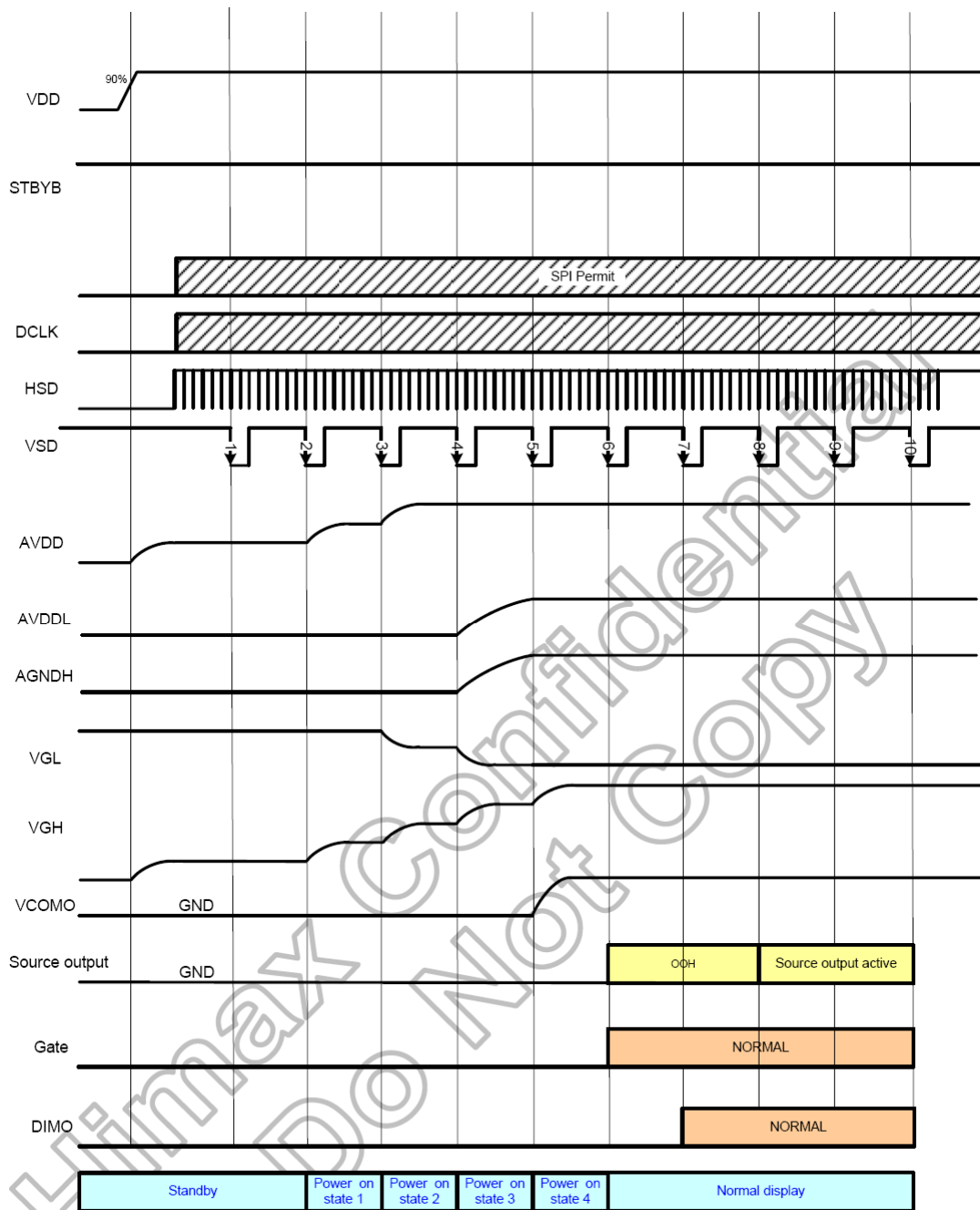

Figure 10.5: 8-bit LVDS Input

8.2 Power on/off

To prevent a latch-up or DC operation of the LCD module, the power on/off sequence shall be as shown in below



9. Standard Specification for Reliability

9.1 Standard Specification for Reliability of LCD Module

Item	Test Conditions	Remark
High temperature storage	Ta=80°C 240hrs	NOTE1 , NOTE4
Low temperature storage	Ta=-30°C 240hrs	NOTE1 , NOTE4
High temperature operation	Ta=70°C 240hrs	NOTE2 , NOTE4
Low temperature operation	Ta=-20°C 240hrs	NOTE2 , NOTE4
Operate at high temperature and humidity	+60°C, 90%RH 240hrs	NOTE4
Thermal Shock	-30°C/30min~+80°C/30min for a total 100 cycles, start with cold temperature and end with high temperature.	NOTE4
Vibration Test	Frequency range:10~55HZ Stroke:1.5mm Swap:10HZ~55HZ~10HZ 2 hours of each direction of X.Y. Z (6 hours for total)	
Mechanical shock	100G 6ms, ± X, ± Y, ± Z 3 times for each direction	
Package vibration test	Random vibration :0.15G*G/HZ from 5-200 HZ,-6dB/Octave from 200-500HZ of each direction of X.Y. Z (6 hours for total)	
Low temperature storage	Height:60cm 1 corner ,3 edges ,6 surfaces	
Low temperature storage	± 2KV ,Human Body Mode, 100pF/1500Ω	

Note 1: Ta is the ambient temperature of samples.

Note 2: Ts is the temperature of panel's surface.

Note 3: In the standard condition, there shall be no practical problem that may affect the display function. After the reliability test, the product only guarantees operation, but don't guarantee all of the cosmetic specification.

Note 4: Before cosmetic and function test, the product must have enough recovery time, at least 2 hours at room temperature.

10. General Precautions

10.1. Safety

- Liquid crystal is poisonous. Do not put it in your mouth. If liquid crystal touches your skin or clothes, wash it off immediately by using soap and water.

10.2. Handling

- The LCD panel is plate glass. Do not subject the panel to mechanical shock or to excessive force on its surface.
- The polarizer attached to the display is easily damaged. Please handle it carefully to avoid scratch or other damages.
- To avoid contamination on the display surface, do not touch the module surface with bare hands.
- Keep a space so that the LCD panels do not touch other components.
- Put cover board such as acrylic board on the surface of LCD panel to protect panel from damages.
- Transparent electrodes may be disconnected if you use the LCD panel under environmental conditions where the condensation of dew occurs.
- Do not leave module in direct sunlight to avoid malfunction of the ICs.

10.3. Static Electricity

- Be sure to ground module before turning on power or operating module.
- Do not apply voltage which exceeds the absolute maximum rating value.

10.4. Storage

- Store the module in a dark room where must keep at $25\pm 10^{\circ}\text{C}$ and 65%RH or less.
- Do not store the module in surroundings containing organic solvent or corrosive gas.
- Store the module in an anti-electrostatic container or bag.

10.5. Cleaning

- Do not wipe the polarizer with dry cloth. It might cause scratch.
- Only use a soft sloth with IPA to wipe the polarizer, other chemicals might permanent damage to the polarizer.

11. Packing Method

----TBD